

### Features

#### Single-chip AM/FM radio solution

- Built-in MCU
- Support analog mechanical tuning

#### Worldwide FM/AM band support

- Maximum two FM bands with configurable frequency range within 32MHz-110MHz
- Maximum two AM bands with configurable frequency range within 500KHz -1750KHz

#### High Sensitivity

- 1.6uVEMF for FM
- 16uVEMF for AM

#### High Fidelity

- SNR (FM/AM): 58dB/55dB(without weighting filter)
- THD: 0.3%

#### Low Supply Current

- 28mA (operating)

#### Integrated tuning indicator

- Programmable sensitivity and hysteresis threshold

#### Low supply voltage

- 2.1V to 3.6V, can be supplied with 2 AAA batteries

#### Integrated low power crystal oscillator

- Support 32.768KHz and 38KHz crystal

#### Arbitrary reference clock supported

- From 30KHz to 40MHz with 1Hz step

#### Small form factor SSOP16L package

#### RoHS Compliant

### Applications

Desktop and portable radio, clock radio, MP3 speaker, campus radio and other applications with mechanical tuning.

### Rev. 1.0

Information furnished by KT Micro is believed to be accurate and reliable. However, no responsibility is assumed by KT Micro for its use, nor for any infringements of patents or other rights of third parties which may result from its use. No license is granted by implication or otherwise under any patent or patent rights of Beijing KT Micro, Ltd.

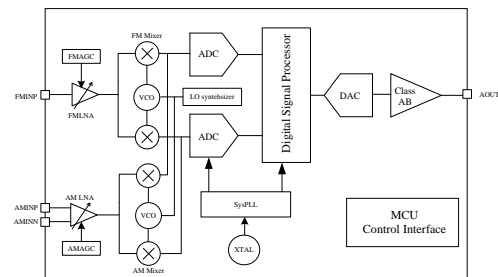

KT0932M System Diagram

### Description

The KT0932M is KT Micro's latest generation of proprietary fully integrated AM/FM receiver chip supporting mechanical tuning without MCU. The new features include improved tuning feel, new Tuning light signal, improved EMI/EMC, improved FM flatness of sensitivity.

Thanks to its advanced architecture, KT0932M offers an excellent user listening experience with high sensitivity, high signal-to-noise ratio, low distortion and low sensitivity to interference.

KT0932M provides direct and simple interface to support mechanical tuning. A pre-programmed low cost EEPROM can be used to configure the radio settings to differentiate product designs and accommodate standards in various regions. No external MCU is required.

Thanks to its high integration level and efficient user interface design, KT0932M lowers the system cost, simplifies design and improves product reliability and manufacturability. KT0932M can operate with two AAA batteries, making it ideal for low-power portable radio.

**Beijing KT Micro, Ltd.**

**BeiWu New Technology Park, Building #4, 23 BeiWuCun Road, Haidian District, Beijing, China.**

**Tel: +86-10-88891955** <http://www.ktmicro.com.cn>

**Fax: +86-10-88891977**

**Copyright © 2013, Beijing KT Micro, Ltd.**

## Table of Content

▪ Features .....	1
▪ Applications.....	1
Rev. 0.1.....	1
▪ Description .....	1
1. Electrical Specification.....	4
2. Typical performance characteristics .....	6
<b>2.1. FM Characteristics.....</b>	<b>6</b>
<b>2.2. AM Characteristics .....</b>	<b>7</b>
3. Pin List .....	8
4. Function Description .....	9
<b>4.1. Overview .....</b>	<b>9</b>
<b>4.2. FM Receiver.....</b>	<b>9</b>
<b>4.3. AM Receiver .....</b>	<b>9</b>
<b>4.4. Operation Bands.....</b>	<b>9</b>
<b>4.5. Crystal and Reference clock.....</b>	<b>9</b>
<b>4.6. Dial Mode for Channel Control .....</b>	<b>10</b>
<b>4.7. Chip Configuration .....</b>	<b>12</b>
<b>4.8. Register Bank .....</b>	<b>13</b>
4.8.1. PLLCFG0 (Address 0x0004) .....	13
4.8.2. PLLCFG1 (Address 0x0005) .....	13
4.8.3. PLLCFG2 (Address 0x0006) .....	13
4.8.4. PLLCFG3 (Address 0x0007) .....	13
4.8.5. SYSCLK_CFG0 (Address 0x0008) .....	13
4.8.6. SYSCLK_CFG1 (Address 0x0009) .....	13
4.8.7. SYSCLK_CFG2 (Address 0x000a).....	13
4.8.8. XTALCFG (Address 0x000d).....	13
4.8.9. RXCFG1 (Address 0x000f).....	14
4.8.10. BANDCFG0 (Address 0x0016) .....	14
4.8.11. BANDCFG2 (Address 0x0018) .....	14
4.8.12. SOUNDCFG (Address 0x0028).....	15
4.8.13. DSPCFG0 (Address 0x002a) .....	15
4.8.14. DSPCFG1 (Address 0x002b) .....	15
4.8.15. DSPCFG6 (Address 0x0030) .....	15
4.8.16. ANACFG (Address 0x004e) .....	16
4.8.17. GPIOCFG0 (Address 0x004f) .....	16
4.8.18. GPIOCFG2 (Address 0x0051) .....	16
4.8.19. AMDSP0 (Address 0x0062).....	16
4.8.20. AMDSP1 (Address 0x0063).....	17
4.8.21. AMDSP7 (Address 0x0069).....	17
4.8.22. GUARD0 (Address 0x006f).....	18
4.8.23. FM1_LOW_CHAN0 (Address 0x0090) .....	18
4.8.24. FM1_LOW_CHAN1 (Address 0x0091) .....	18
4.8.25. FM1_CHAN_NUM0 (Address 0x0092).....	18
4.8.26. FM1_CHAN_NUM1 (Address 0x0093).....	18
4.8.27. FM2_LOW_CHAN0 (Address 0x0094) .....	18
4.8.28. FM2_LOW_CHAN1 (Address 0x0095) .....	19
4.8.29. FM2_CHAN_NUM0 (Address 0x0096).....	19
4.8.30. FM2_CHAN_NUM1 (Address 0x0097).....	19
4.8.31. AM1_LOW_CHAN0 (Address 0x0098).....	19
4.8.32. AM1_LOW_CHAN1 (Address 0x0099).....	19
4.8.33. AM1_CHAN_NUM0 (Address 0x009a).....	19
4.8.34. AM1_CHAN_NUM1 (Address 0x009b) .....	20
4.8.35. AM2_LOW_CHAN0 (Address 0x009c).....	20
4.8.36. AM2_LOW_CHAN1 (Address 0x009d).....	20
4.8.37. AM2_CHAN_NUM0 (Address 0x009e).....	20
4.8.38. AM2_CHAN_NUM1 (Address 0x009f).....	20
4.8.39. GUARD2 (Address 0x00a0) .....	20
4.8.40. GUARD3 (Address 0x00a1) .....	21



4.8.41. GUARD4 (Address 0x00a2) ..... 21  
4.8.42. GUARD5 (Address 0x00a3) ..... 21  
5. Typical Application Circuit ..... 22  
6. Package Outline ..... 23  
7. Order Information ..... 24  
8. Revision History ..... 24  
9. Contact Information ..... 25

# 1. Electrical Specification

**Table 1: Operation Condition**

Parameter	Symbol	Operating Condition	Min	Typ	Max	Units
Power Supply	AVDD	Relative to AVSS	2.1	3.3	3.6	V
Ambient Temperature	Ta		-30	25	70	°C

**Table 2: DC Characteristics**

Parameter	Symbol	Test/Operating Condition	Min	Typ	Max	Units
Current Consumption	FM Mode	I <sub>FM</sub>	-	-	30	mA
	AM Mode	I <sub>AM</sub>	-	-	29	mA

**Table 3: FM Receiver Characteristics**

(Unless otherwise noted Ta = -30~70°C, VDD= 2.1V to 3.6V)

Parameter	Symbol	Test/Operating Condition	Min	Typ	Max	Units
FM Frequency Range	F <sub>rx</sub>		32		110	MHz
Sensitivity <sup>1,2</sup>	Sen	(S+N)/N=26dB		1.6	2	uVemf
Input referred 3 <sup>rd</sup> Order Intermodulation Production <sup>3,4</sup>	IIP3			100		dBuVE MF
Adjacent Channel Selectivity		± 200KHz	40		51	dB
Alternate Channel Selectivity		± 400KHz	50		70	dB
Image Rejection Ratio				43		dB
AM suppression				50		dB
RCLK frequency Range			30	32.768	40,000	KHz
RCLK frequency tolerance <sup>7</sup>			-100		100	ppm
Audio Output Voltage <sup>1,2,3</sup>		32ohm load	-	190	-	mV <sub>RMS</sub>
Audio Band Limits <sup>1,3</sup>		± 3dB	30		15k	Hz
Audio S/N <sup>1,2,3</sup>		Without weighting filter	55	58		dB
Audio THD <sup>1,3,5</sup>				0.3		%
De-emphasis Time Constant		DE=0		75		µs
		DE=1		50		µs
Audio Common Mode Voltage			0.85	1.35	1.6	V
Audio Output Load Resistance	R <sub>L</sub>	Single-ended		32		Ω
Seek/Tune Time					50	ms
Power-up Time			200		600	ms

Notes:

- FMOD=1KHz, 75us de-emphasis
- ΔF=22.5KHz
- V<sub>EMF</sub>=1mV, F<sub>rx</sub>=32MHz~110MHz
- AGCD=1
- ΔF=75KHz
- VOLUME<4:0>=11111
- The supported RCLK frequency is not continuous. Please refer to application notes.



**Table 4: AM Receiver Characteristics**  
 (Unless otherwise noted  $T_a = -30\sim 70^{\circ}\text{C}$ ,  $V_{DD} = 2.1\text{V to } 3.6\text{V}$ )

Parameter	Symbol	Test/Operating Condition	Min	Typ	Max	Units
AM Frequency Range	$F_{rx}$		500		1750	KHz
Sensitivity <sup>1,2</sup>	Sen	(S+N)/N=26dB		15		$\mu\text{VEMF}$
Audio Output Voltage <sup>1,2,3,4</sup>		32ohm load		190		$\text{mV}_{\text{RMS}}$
Audio S/N <sup>1,2,3,4</sup>				55		dB
Audio THD <sup>1,2,4</sup>				0.3	0.6	%
Antenna inductance	L		360	-	620	$\mu\text{H}$

Notes:  
 1. F<sub>MOD</sub>=1KHz  
 2. Modulation index is 30%  
 3.  $V_{\text{EMF}}=1\text{mV}$ ,  $F_{\text{rx}}=500\text{KHz}\sim 1750\text{KHz}$   
 4. VOLUME<4:0>=11111

CONFIDENTIAL

## 2. Typical performance characteristics

### 2.1. FM Characteristics

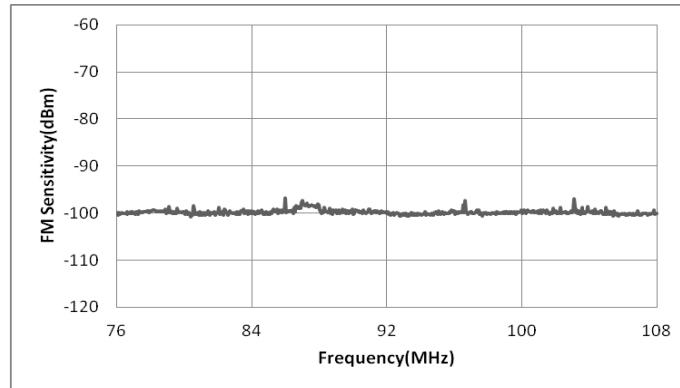

Test condition ( $T_a = 27^\circ\text{C}$ ,  $V_{DD} = 3.0\text{V}$ , Crystal=32.768KHz, SNR=40dB, FMOD=1KHz, 75us de-emphasis,  $\Delta F = 22.5\text{KHz}$ , Without weighting filter)

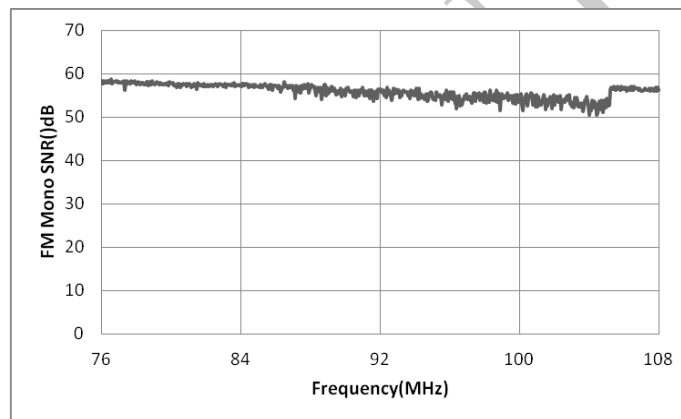

Test condition ( $T_a = 27^\circ\text{C}$ ,  $V_{DD} = 3.0\text{V}$ , Crystal=32.768KHz, FMOD=1KHz, 75us de-emphasis,  $\Delta F = 22.5\text{KHz}$ ,  $P_{in} = 60\text{dBu VEMF}$ , Without weighting filter)

## 2.2. AM Characteristics

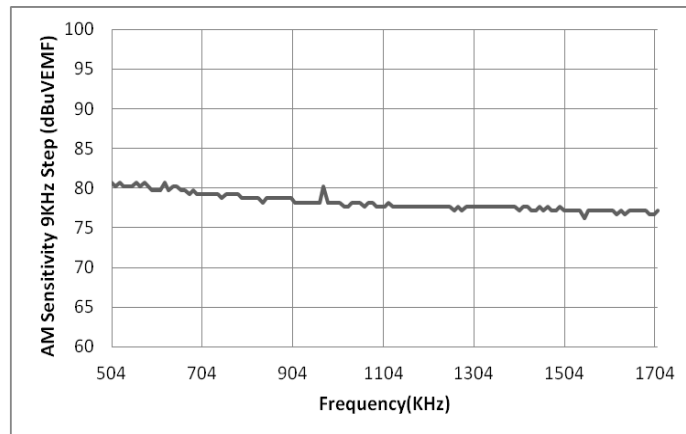

Test condition ( $T_a = 27^\circ\text{C}$ ,  $V_{DD} = 3.0\text{V}$ , Crystal=32.768KHz, SNR=20dB, F<sub>MOD</sub>=1 KHz, AM modulation index=30%, Without weighting filter, ferrite antenna =420uH, distance between Tx&Rx antenna=60cm )

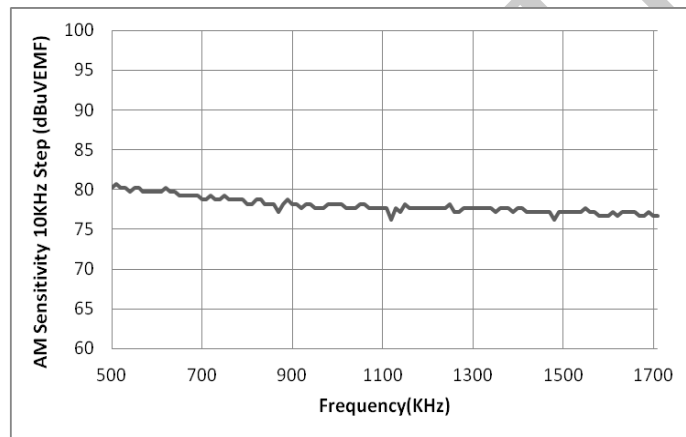

Test condition ( $T_a = 27^\circ\text{C}$ ,  $V_{DD} = 3.0\text{V}$ , Crystal=32.768KHz, SNR=20dB, F<sub>MOD</sub>=1 KHz, AM modulation index=30%, Without weighting filter, ferrite antenna =420uH, distance between Tx&Rx antenna=60cm )

### 3. Pin List

Table 5: Pin list

Pin Num	Pin Name	I/O Type	Description
1	AMINN	Analog I/O	AM RF negative input.
2	AMINP	Analog I/O	AM RF positive input.
3	RFINP	RF Input	FM RF input
4	RFGND	RF Ground	RF ground.
5	DVSS	Digital Ground	Digital ground.
6	DVDD	Digital Power	Digital Power supply.
7	DVSS	Digital Ground	Digital ground.
8	TUNING	Digital Output	Tuning indicator.
9	CH	Analog Input	Channel adjustment
10	AM_FM	Digital Output	AM/FM switching control.
11	SPAN	Analog Input	Band switching control pin.
12	AOUT	Analog Output	Audio output.
13	AVSS	Analog Ground	Analog ground.
14	XI/RCLK	Analog I/O	Crystal.
15	XO	Analog I/O	Crystal.
16	AVDD	Analog Power	Power supply

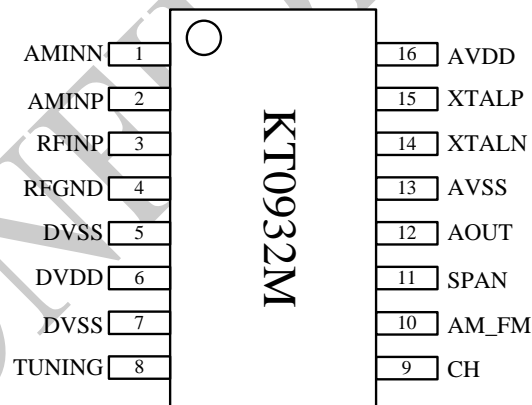

Figure 1: KT0932M Pin assignment (Top view)



## 4. Function Description

### 4.1. Overview

KT0932M offers a true single-chip, full-band FM/AM and versatile radio solution by minimizing the external components and offering a variety of configurations.

### 4.2. FM Receiver

The FM receiver is based on the architecture of KT Micro's latest generation FM receiver chips in mass production. There are no external filters or frequency-tuning devices thanks to a proprietary digital low-IF architecture consisting of a fully-integrated LNA, an automatic gain control (AGC), a set of high-performance ADCs, high-quality analog and digital filters, and an on-chip low-noise self-tuning VCO. The on-chip high-fidelity Class-AB driver further eliminates the need for external audio amplifiers.

### 4.3. AM Receiver

The AM Receiver employs a similar digital low IF architecture and shares many circuits with the FM receiver. The AM receiver supports arbitrary frequency range from 500KHz to 1750KHz. The AM channel spacing can be set to 1KHz, 9KHz or 10KHz to address applications in different regions. The bandwidth of the channel filter can be set to 1KHz to 5KHz to suit various requirements by setting register FLT\_SEL <2:0>.

The AM receiver in KT0932M can provide accurate and automatic antenna tuning without manual alignment within the frequency range of 500KHz to 1750KHz. It supports ferrite loop antenna with value between 360uH and 620uH.

### 4.4. Operation Bands

KT0932M supports wide FM band and AM bands. The FM receiver covers frequencies from 32MHz to 110MHz. The AM band is from 500KHz to 1750KHz.

### 4.5. Crystal and Reference clock

KT0932M integrates a low frequency crystal oscillator that supports 32.768KHz or 38KHz crystals. Alternatively a CMOS level external reference clock may be used by setting the RCLK\_EN register to 1 and setting FPFD<19:0> according to the frequency of the reference clock. The FPFD<19:0> is the frequency value in the unit of 1/16Hz. In order to illuminate the usage of these bits clearly some examples are given in Table 6.

**Table 6: Examples using different crystal or reference clock**

	RCLK_EN	FPFD<19:16>	FPFD<15:0>	DIVIDERP<10:0>	DIVIDERN<10:0>
32768Hz crystal	0	0x08	0x0000	0x0001	0x029C
38KHz crystal	0	0x09	0x4700	0x0001	0x0240

32.768KHz reference clock	1	0x08	0x0000	0x0001	0x029C
75KHz reference clock	1	0x09	0x27C0	0x0002	0x0247
4.2336 MHz reference clock	1	0x07	0x5499	0x008D	0x02D9
12MHz reference clock	1	0x07	0xD000	0x0177	0x02AC
24MHz reference clock	1	0x07	0xD000	0x02EE	0x02AC
40MHz reference clock	1	0x07	0xD000	0x04E2	0x02AC

#### 4.6. Dial Mode for Channel Control

KT0932M supports a unique Dial Mode whose application circuit is shown in Figure 5.

The dial is implemented by a variable resistor with the center tap connected to the chip. KT0932M measures the ratio of two parts of the variable resistor and maps the result to channel frequency.

The channel controller enters dial mode by setting register CH\_PIN<1:0> to b'10. The illustration circuit is shown in Figure 2. If the center tap of the variable resistor is located in the white area, the tuned channel could be expressed as:

$$f_{tune} = \left( \frac{X}{X+Y} (N_{chan} + 2 \times N_{guard}) - N_{guard} \right) \times f_{step} + F_{low}$$

Where  $f_{step}$  is the channel step, set by registers FM1\_SPACE<1:0>, FM2\_SPACE<1:0>, AM1\_SPACE<1:0> and AM2\_SPACE<1:0>.  $N_{chan}$  is set by the registers FM1\_CHAN\_NUM<11:0>, FM2\_CHAN\_NUM<11:0>, AM1\_CHAN\_NUM<10:0> and AM2\_CHAN\_NUM<10:0>.  $F_{low}$  is set by the registers FM1\_LOW\_CHAN<11:0>, FM2\_LOW\_CHAN<11:0>, AM1\_LOW\_CHAN<10:0> and AM2\_LOW\_CHAN<10:0>.

$N_{guard}$  is the number of guard channel in channel step to prevent mechanical limit of the wheels. Each band's guard number can be configured by register FM1\_GUARD<7:0>, FM2\_GUARD<7:0>, AM1\_GUARD<7:0> and AM2\_GUARD<7:0>, separately. When the center tap goes in the shaded guard area, the tuned channel stays at the upper or lower bound of band.

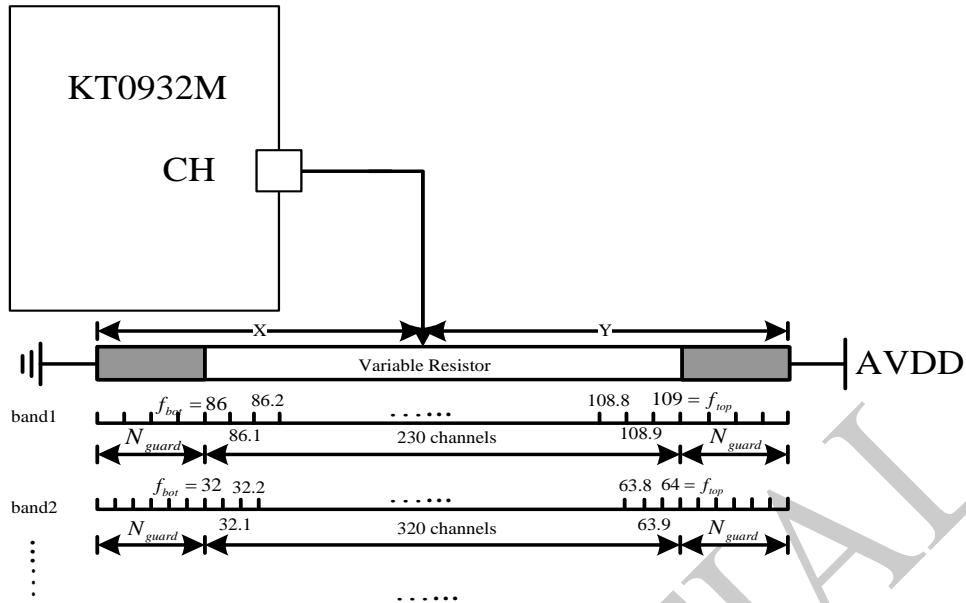

**Figure 2: CH pin connection in dial-mode**

The bands can be changed by band-switch in dial-mode by setting register SPAN\_PIN<1:0> to b'10. The application circuit together with recommended resistor values is shown in Figure 4.

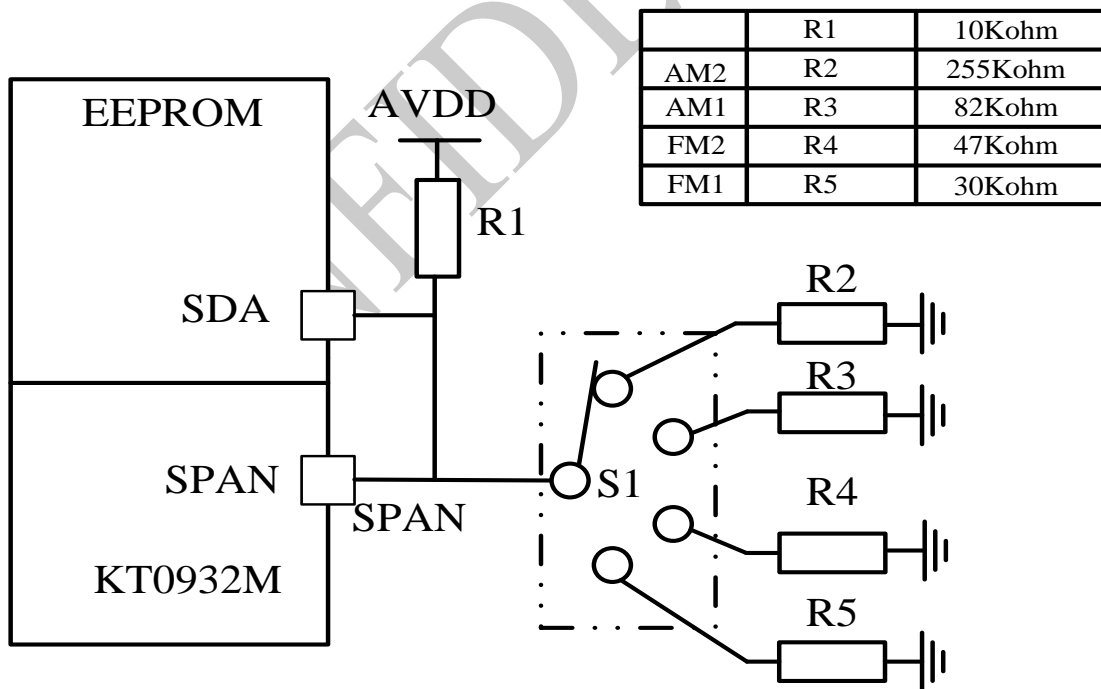

**Figure 4: SPAN pin connection in dial-mode**

#### 4.7. Chip Configuration

An I2C master interface is integrated in KT0932M and can be used to initialize and operate the chip together with an external EEPROM (e.g. 24LC02). The initialization information is written into the EEPROM beforehand. When powered on, KT0932M will readout all the data stored in the EEPROM and write them into internal register bank. The mapping relationship of the register bit between KT0932M internal register bank and 24LC02 can be found in Table 7. The effective device address for EEPROM is from 000(A2:A0) to 110.

**Table 7: Register Bits Mapping Relationship between 24LC02 and KT0932M**

<b>24LC02</b>		<b>KT0932M</b>	
address	bits	address	bits
0x00	D7:D0	0x00	D7:D0
0x01	D7:D0	0x01	D7:D0
0x02	D7:D0	0x02	D7:D0
0x03	D7:D0	0x03	D7:D0
...	...	...	...
...	...	...	...
0xFE	D7:D0	0xFE	D7:D0
0xFF	D7:D0	0xFF	D7:D0

CONFIDENTIAL

## 4.8. Register Bank

### 4.8.1. PLLCFG0 (Address 0x0004)

Bit	Name	Access	Default Value	Functional Description
7:3	Reserved	R	0000_0	
2:0	DIVIDERP<10:8>	RW	000	PLL divider P configuration.

### 4.8.2. PLLCFG1 (Address 0x0005)

Bit	Name	Access	Default Value	Functional Description
7:0	DIVIDERP<7:0>	RW	0x01	PLL divider P configuration.

### 4.8.3. PLLCFG2 (Address 0x0006)

Bit	Name	Access	Default Value	Functional Description
7:3	Reserved	RW	0000_0	Reserved
2:0	DIVIDERN<10:8>	RW	010	PLL divider N configuration.

### 4.8.4. PLLCFG3 (Address 0x0007)

Bit	Name	Access	Default Value	Functional Description
7:0	DIVIDERN<7:0>	RW	0x9C	PLL divider N configuration.

### 4.8.5. SYSCLK\_CFG0 (Address 0x0008)

Bit	Name	Access	Default Value	Functional Description
7:4	Reserved	RW	0000_0	
3:0	FPPD<19:16>	RW	1000	Phase-detection frequency. FPPD<19:0> = External xtal clock or RCLK frequency / DIVIDERP

### 4.8.6. SYSCLK\_CFG1 (Address 0x0009)

Bit	Name	Access	Default Value	Functional Description
7:0	FPPD<15:8>	RW	0x00	Phase-detection frequency. FPPD<19:0> = External xtal clock or RCLK frequency / DIVIDERP

### 4.8.7. SYSCLK\_CFG2 (Address 0x000a)

Bit	Name	Access	Default Value	Functional Description
7:0	FPPD<7:0>	RW	0x00	Phase-detection frequency. FPPD<19:0> = External xtal clock or RCLK frequency / DIVIDERP

### 4.8.8. XTALCFG (Address 0x000d)

Bit	Name	Access	Default Value	Functional Description
7:5	Reserved	RW	110	
4	RCLK_EN	RW	0	Reference clock enable.

Bit	Name	Access	Default Value	Functional Description
				0 = crystal 1 = external reference clock.
3:0	Reserved	RW	0011	

#### 4.8.9. RXCFG1 (Address 0x000f)

Bit	Name	Access	Default Value	Functional Description
7:5	Reserved	R	000	
4:0	VOLUME<4:0>	RW	1_1111	Volume control bits: 11111 = 0dB 11110 = -2dB/ 11101 = -4dB ..... 00010 = -58dB 00001 = -60dB 00000 = mute

#### 4.8.10. BANDCFG0 (Address 0x0016)

Bit	Name	Access	Default Value	Functional Description
7	SPAN_MODE	RW	1	SPAN control mode selection 0 = AM/FM switching controlled by AM_FM pin 1 = AM/FM switching controlled by SPAN pin, Not controlled by AM_FM pad or AM_FM register
6:0	Reserved	RW	000_1010	

#### 4.8.11. BANDCFG2 (Address 0x0018)

Bit	Name	Access	Default Value	Functional Description
7:6	FM2_SPACE<1:0>	RW	01	<b>FM band 2 space selection.</b> B'00 = 200 kHz (USA, Europe) B'01 = 100KHz (Europe, Japan) B'10 = 50KHz B'11 = 50KHz
5:4	FM1_SPACE<1:0>	RW	01	<b>FM band 1 space selection.</b> B'00 = 200 kHz (USA, Europe) B'01 = 100KHz (Europe, Japan) B'10 = 50KHz B'11 = 50KHz
3:2	AM2_SPACE<1:0>	RW	10	<b>AM band 2 space selection.</b> B'00 = 1kHz B'01 = 9kHz B'10 = 10kHz B'11 = 10kHz
1:0	AM1_SPACE<1:0>	RW	01	AM band 1 space selection. B'00 = 1kHz B'01 = 9kHz B'10 = 10kHz B'11 = 10kHz

**4.8.12. SOUNDCFG (Address 0x0028)**

Bit	Name	Access	Default Value	Functional Description
7:6	Reserved	R	00	
5:4	BASS<1:0>	RW	00	Bass boost effect mode selection 00 = Bypass 01 = 9.4 dB@70Hz 10 = 13.3dB@70Hz 11 = 18.2dB@70Hz
3:0	Reserved	RW	1101	

**4.8.13. DSPCFG0 (Address 0x002a)**

Bit	Name	Access	Default Value	Functional Description
7	Reserved	RW	1	
6:4	FM_GAIN<2:0>	RW	000	<b>Audio gain for FM audio processor.</b> 000 = 0dB 001 = 3.5dB 010 = 6dB 011 = 9.5dB 100 = -2.5dB 101 = -3.66dB 110 = -6dB 111 = -8.5dB
3	Reserved	RW	0000	

**4.8.14. DSPCFG1 (Address 0x002b)**

Bit	Name	Access	Default Value	Functional Description
7:4	Reserved	RW	000	
3	DE	RW	0	De-emphasis 0 =75us. Used in USA. 1=50us. Used in Europe, Australia, Japan.
2:0	Reserved	RW	000	

**4.8.15. DSPCFG6 (Address 0x0030)**

Bit	Name	Access	Default Value	Functional Description
7	Reserved	RW	101	
4:0	FM_RSSI_BIAS<4:0>	RW	0_0000	<b>FM RSSI offset.</b> 10000 = -16dB 10001 = -15dB ..... 11110 = -2dB 11111 = -1dB 00000 = 0dB 00001 = 1dB ..... 01111 = 15dB

**4.8.16. ANACFG (Address 0x004e)**

Bit	Name	Access	Default Value	Functional Description
7:6	Reserved	RW	00	
5:4	DEPOP_TC <1:0>	RW	00	De-pop time constant. 00 = 250ms 01 = 500ms 10 = 750ms 11 = 1s
3	Reserved	RW	0	
2:0	AUDV_DCLVL<2:0>	RW	101	Audio Output Common Voltage: 000=0.85v 001=0.91v 010= 1.05v 011= 1.15v 100= 1.20v 101=1.35v 110=1.50v 111=1.60v

**4.8.17. GPIOCFG0 (Address 0x004f)**

Bit	Name	Access	Default Value	Functional Description
7	Reserved	RW	1	
6:4	AM_FM_PIN <2:0>	RW	010	<b>AM_FM Pin function control</b> 000 = Reserved 001 = Key controlled AM/FM selection input 010 = Switch controlled AM/FM selection input 011 = AM_FM output 1. 100 = AM_FM output 0.
3:0	Reserved	R	0000	

**4.8.18. GPIOCFG2 (Address 0x0051)**

Bit	Name	Access	Default Value	Functional Description
7:6	Reserved	RW	B'00	
5:4	SPAN_PIN <1:0>	RW	B'10	SPAN pin function control 00 = Reserved 01 = Reserved 10= Dial control bands selection input 11 = Reserved
3:2	Reserved	RW	B'00	
1:0	CH_PIN <1:0>	RW	B'10	CH pin function control 00 = high Z 01 = Reserved 10 = Dial controlled channel increase / decrease input 11 = Reserved

**4.8.19. AMDSP0 (Address 0x0062)**

Bit	Name	Access	Default Value	Functional Description
7:4	AM_GAIN<3:0>	RW	0110	<b>Audio gain for AM audio processor.</b>





Bit	Name	Access	Default Value	Functional Description
				0000 = 6dB 0001 = 3dB 0010 = 0dB 0011 = -3dB 0100 = -6dB 0101 = -9dB 0110 = -12dB 0111 = -15dB 1000 = -18dB
3	Reserved	R	0	
2:0	FLT_SEL<2:0>	RW	001	AM Channel Filter Bandwidth Selection: 000=1.2KHz 001=2.4KHz 010=3.6KHz 011=4.8KHz 100=6.0KHz

**4.8.20. AMDSP1 (Address 0x0063)**

Bit	Name	Access	Default Value	Functional Description
7:5	Reserved	R	000	
4:0	AM_RSSI_BIAS<4:0>	RW	0_0000	<b>AM RSSI offset.</b> 10000 = -16dB 10001 = -15dB ..... 11110 = -2dB 11111 = -1dB 00000 = 0dB 00001 = 1dB ..... 01111 = 15dB

**4.8.21. AMDSP7 (Address 0x0069)**

Bit	Name	Access	Default Value	Functional Description
7:4	Reserved	RW	1000	
3:0	AM_VOLUME<3:0>	RW	1110	AM Volume Control bits: 4'b1111= 0dB 4'b1110=-0.5dB 4'b1101=-1.0dB 4'b1100= -1.5dB 4'b1011= -2.0dB 4'b1010= -2.5dB 4'b1001= -3.0dB 4'b1000= -3.5dB 4'b0111=-4.0dB 4'b0110= -4.5dB 4'b0101= -5.0dB 4'b0100= -5.5dB 4'b0011= -6.0dB 4'b0010=-6.5dB 4'b0001=-7.0dB 4'b0000= -7.5dB

**4.8.22. GUARD0 (Address 0x006f)**

Bit	Name	Access	Default Value	Functional Description
7:4	Reserved	R	0000	
3:0	SPAN_GUARD<3:0>	RW	0010	Span guard range in dial mode.

**4.8.23. FM1\_LOW\_CHAN0 (Address 0x0090)**

Bit	Name	Access	Default Value	Functional Description
7:4	Reserved	R	0000	
3:0	FM1_LOW_CHAN<11:8>	RW	0110	Low edge frequency of FM1 band with 50KHz per LSB and default is 86MHz(0x06B8). It should be a value between 32MHz (0x280) and 110MHz (0x898).

**4.8.24. FM1\_LOW\_CHAN1 (Address 0x0091)**

Bit	Name	Access	Default Value	Functional Description
7:0	FM1_LOW_CHAN<7:0>	RW	0xB8	Low edge frequency of FM1 band with 50KHz per LSB and default is 86MHz(0x06B8). It should be a value between 32MHz (0x280) and 110MHz (0x898).

**4.8.25. FM1\_CHAN\_NUM0 (Address 0x0092)**

Bit	Name	Access	Default Value	Functional Description
7:4	Reserved	R	0000	
3:0	FM1_CHAN_NUM<11:8>	RW	0000	Channel number of FM1 band and the channel number is FM1_CHAN_NUM<11:0> + 1. If FM1_CHAN_NUM<11:0> is set to 0, only one channel is defined.

**4.8.26. FM1\_CHAN\_NUM1 (Address 0x0093)**

Bit	Name	Access	Default Value	Functional Description
7:0	FM1_CHAN_NUM<7:0>	RW	0xe6	Channel number of FM1 band and the channel number is FM1_CHAN_NUM<11:0> + 1. If FM1_CHAN_NUM<11:0> is set to 0, only one channel is defined.

**4.8.27. FM2\_LOW\_CHAN0 (Address 0x0094)**

Bit	Name	Access	Default Value	Functional Description
7:4	Reserved	R	B'0000	
3:0	FM2_LOW_CHAN<11:8>	RW	B'0101	Low edge frequency of FM2 band with 50KHz per LSB and default is 64MHz(0x0500). It should be a value between 32MHz (0x280) and 110MHz (0x898).



**4.8.28. FM2\_LOW\_CHAN1 (Address 0x0095)**

Bit	Name	Access	Default Value	Functional Description
7:0	FM2_LOW_CHAN <7:0>	RW	0	Low edge frequency of FM2 band with 50KHz per LSB and default is 64MHz(0x0500). It should be a value between 32MHz (0x280) and 110MHz (0x898).

**4.8.29. FM2\_CHAN\_NUM0 (Address 0x0096)**

Bit	Name	Access	Default Value	Functional Description
7:4	Reserved	R	B'0000	
3:0	FM2_CHAN_NUM <11:8>	RW	B'0001	Channel number of FM2 band and the channel number is FM2_CHAN_NUM<11:0> + 1. If FM2_CHAN_NUM<11:0> is set to 0, only one channel is defined.

**4.8.30. FM2\_CHAN\_NUM1 (Address 0x0097)**

Bit	Name	Access	Default Value	Functional Description
7:0	FM2_CHAN_NUM <7:0>	RW	0x0e	Channel number of FM2 band and the channel number is FM2_CHAN_NUM<11:0> + 1. If FM2_CHAN_NUM<11:0> is set to 0, only one channel is defined.

**4.8.31. AM1\_LOW\_CHAN0 (Address 0x0098)**

Bit	Name	Access	Default Value	Functional Description
7:3	Reserved	R	0	
2:0	AM1_LOW_CHAN <10:8>	RW	001	Low edge frequency of AM1 band with 1KHz per LSB and default is 504KHz(0x01F8). It should be a value between 500KHz (0x1F4) and 1750KHz (0x6D6)

**4.8.32. AM1\_LOW\_CHAN1 (Address 0x0099)**

Bit	Name	Access	Default Value	Functional Description
7:0	AM1_LOW_CHAN <7:0>	RW	0xf8	Low edge frequency of AM1 band with 1KHz per LSB and default is 504KHz(0x01F8). It should be a value between 500KHz (0x1F4) and 1750KHz (0x6D6)

**4.8.33. AM1\_CHAN\_NUM0 (Address 0x009a)**

Bit	Name	Access	Default Value	Functional Description
7:3	Reserved	R	B'00000	
2:0	AM1_CHAN_NUM <10:8>	RW	000	Channel number of AM1 band and the channel number is AM1_CHAN_NUM<10:0> + 1. If



Bit	Name	Access	Default Value	Functional Description
				AM1_CHAN_NUM<10:0> is set to 0, only one channel is defined.

**4.8.34. AM1\_CHAN\_NUM1 (Address 0x009b)**

Bit	Name	Access	Default Value	Functional Description
7:0	AM1_CHAN_NUM<7:0>	RW	0x86	Channel number of AM1 band and the channel number is AM1_CHAN_NUM<10:0> + 1. If AM1_CHAN_NUM<10:0> is set to 0, only one channel is defined.

**4.8.35. AM2\_LOW\_CHAN0 (Address 0x009c)**

Bit	Name	Access	Default Value	Functional Description
7:3	Reserved	R	B'000	
2:0	AM2_LOW_CHAN<10:8>	RW	B'001	Low edge frequency of AM2 band with 1KHz per LSB and default is 500KHz(0x01F4). It should be a value between 500KHz (0x1F4) and 1750KHz (0x6D6)

**4.8.36. AM2\_LOW\_CHAN1 (Address 0x009d)**

Bit	Name	Access	Default Value	Functional Description
7:0	AM2_LOW_CHAN<7:0>	RW	0xF4	Low edge frequency of AM2 band with 1KHz per LSB and default is 500KHz(0x01F4). It should be a value between 500KHz (0x1F4) and 1750KHz (0x6D6)

**4.8.37. AM2\_CHAN\_NUM0 (Address 0x009e)**

Bit	Name	Access	Default Value	Functional Description
7:3	Reserved	R	00000	
2:0	AM2_CHAN_NUM<10:8>	RW	000	Channel number of AM2 band and the channel number is AM2_CHAN_NUM<10:0> + 1. If AM2_CHAN_NUM<10:0> is set to 0, only one channel is defined.

**4.8.38. AM2\_CHAN\_NUM1 (Address 0x009f)**

Bit	Name	Access	Default Value	Functional Description
7:0	AM2_CHAN_NUM<7:0>	RW	0x7d	Channel number of AM2 band and the channel number is AM2_CHAN_NUM<10:0> + 1. If AM2_CHAN_NUM<10:0> is set to 0, only one channel is defined.

**4.8.39. GUARD2 (Address 0x00a0)**

Bit	Name	Access	Default Value	Functional Description
-----	------	--------	---------------	------------------------



Bit	Name	Access	Default Value	Functional Description
7:0	FM1_GUARD<7:0 >	RW	0x17	FM1 guard range in dial mode.

**4.8.40. GUARD3 (Address 0x00a1)**

Bit	Name	Access	Default Value	Functional Description
7:0	FM2_GUARD<7:0 >	RW	0x1B	FM2 guard range in dial mode.

**4.8.41. GUARD4 (Address 0x00a2)**

Bit	Name	Access	Default Value	Functional Description
7:0	AM1_GUARD<7: 0>	RW	0x78	AM1 guard range in dial mode.

**4.8.42. GUARD5 (Address 0x00a3)**

Bit	Name	Access	Default Value	Functional Description
7:0	AM2_GUARD<7: 0>	RW	0x78	AM2 guard range in dial mode.

CONFIDENTIAL

## 5. Typical Application Circuit

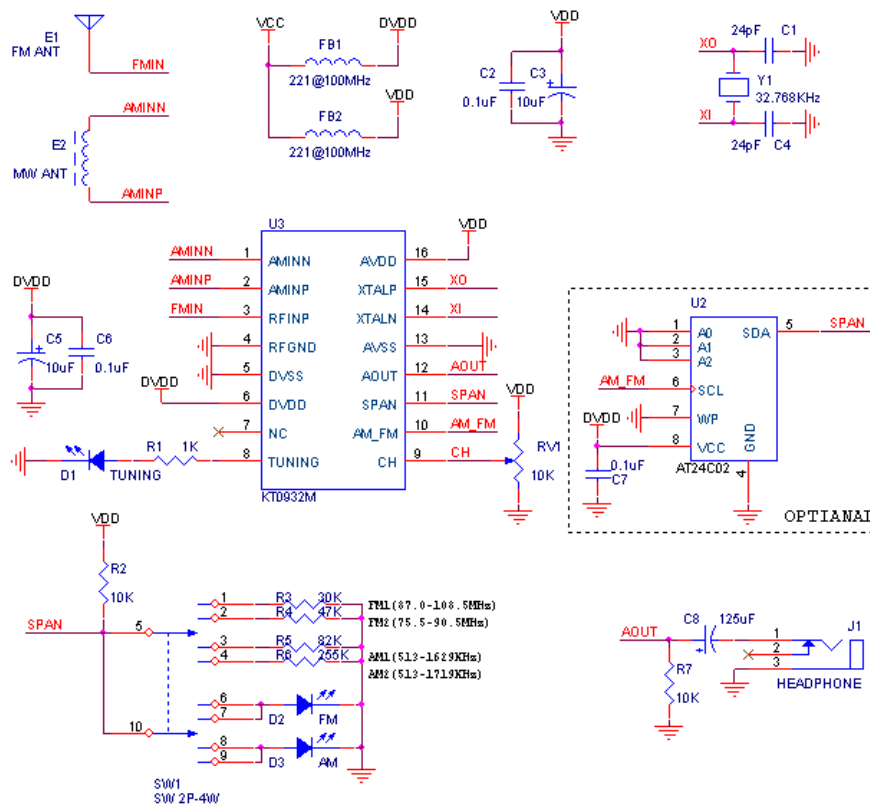
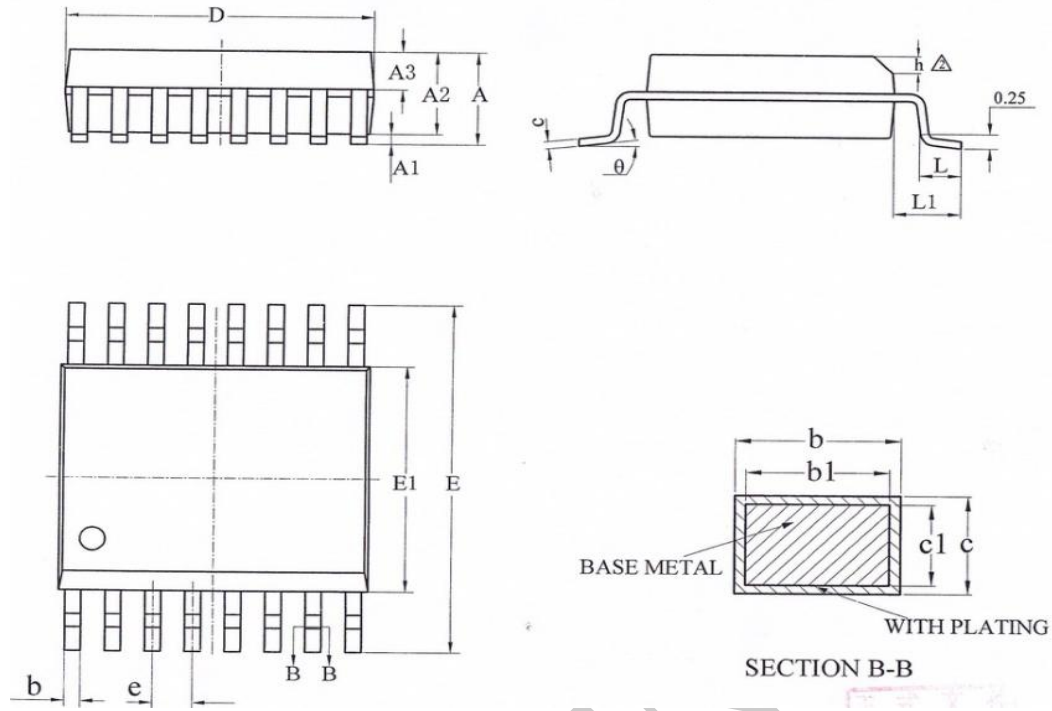

**Figure 5: Typical Application Circuits for Dial Mode**

Components	Description	Value
C2,C6,C7	Supply decoupling capacitor.	0.1uF
C3,C5	Supply decoupling capacitor.	10uF
C8	AC coupling capacitor.	125uF
C1,C4	Crystal oscillator capacitor.	24pF
D1	Tuning indicator light.	LED
D2	FM indicator light.	LED
D3	Stereo indicator light.	LED
E1	FM ferrite antenna.	
E2	AM ferrite antenna.	420uH
FB1,FB2	Ferrite bead.	221 @100MHz
J1	Phone Jack	
R1,R2,R7	Resistor.	10Kohm
R3	Resistor network for band switch.	30Kohm
R4	Resistor network for band switch.	47Kohm
R5	Resistor network for band switch.	82Kohm
R6	Resistor network for band switch.	255Kohm
RV1	Variable resistor.	10Kohm
SW1	Band switch.	Single-pole/Multiple-Throw switch.
U2	EEPROM for chip configuration.	AT24C02
U3	AM/FM receiver	KT0932M
Y1	Crystal.	32.768KHz



### 6. Package Outline



SYMBOL	MILLIMETER		
	MIN	NOM	MAX
A	-	-	1.75
A1	0.10	-	0.225
A2	1.30	1.40	1.50
A3	0.50	0.60	0.70
b	0.24	-	0.30
b1	0.23	0.254	0.28
c	0.20	-	0.25
c1	0.19	0.20	0.21
D	4.80	4.90	5.00
E	5.80	6.00	6.20
E1	3.80	-	4.00
e	0.635BSC		
h	0.25	-	0.50
L	0.50	0.65	0.80
L1	1.05BSC		
theta	0	-	8°



## 7. Order Information

Part number	Description	Package	MPQ
KT0932M	3 <sup>rd</sup> generation monolithic digital AM/FM receiver	SSOP16L(0.635-D1.4), Pb free	2500 pcs

## 8. Revision History

V1.0 First release.

CONFIDENTIAL





## **9. Contact Information**

### **Beijing KT Micro, Ltd.**

BeiWu New Technology Park, Building #4, 23 BeiWuCun Road, Haidian District,  
Beijing, China

Zip Code: 100195

Tel: +86-10-88891955

+86-10-88891947(direct)

Fax: +86-10-88891977

Email: [sales@ktmicro.com](mailto:sales@ktmicro.com)

### **Beijing KT Micro, Ltd. (US Office)**

999 Corporate Drive, Suite 170

Ladera Ranch, CA 92694

USA

Tel: 949-713-4000

Fax: 949-713-4004

Email: [sales@ktmicro.com](mailto:sales@ktmicro.com)

CONFIDENTIAL