

GENERAL DESCRIPTION

The ft2850 is a 5W **Dual-Pump™** Class-AB/D/G audio power amplifier with automatic level control (ALC) for portable audio applications. It integrates Class-AB and Class-D audio power amplifiers with a Class-G charge pump regulator based upon proprietary **Dual-Pump™** topology. It operates from 3.2V to 4.6V supply. With a supply voltage at 3.7V, it can deliver an output power of 5W with 10% THD+N, or an ALC output power of 4W with 0.6% THD+N, into a 4Ω speaker load.

In ft2850, the power supply rail of the audio amplifier's output stage is adaptively boosted and regulated by a Class-G charge pump regulator, allowing much higher audio loudness than a stand-alone one directly connected to the battery. The adaptive nature of the Class-G charge pump regulator, whose output voltage varies dynamically in response to the level of the audio output, improves overall power efficiency and extends battery life when playing music. The higher output power and greater power efficiency resulted from the Class-G charge pump regulator make ft2850 an ideal audio solution for battery-powered electronic devices.

To facilitate various applications, the ft2850 provides three types of audio amplifier outputs, i.e., Class-AB, Class-D, and Class-G. For typical applications, the Class-D/G audio output is preferred for its high efficiency. The Class-AB audio output can be chosen to alleviate design complexities for applications where minimum FM radio interference is required.

The ft2850 features ALC that constantly monitors and safeguards the audio output against the boosted supply voltage, preventing output clipping distortion, excessive power dissipation, or speaker over-load. Once an over-level condition is detected, the ALC lowers the voltage gain of the audio amplifier proportionally to limit the peak audio output voltage.

FEATURES

- I Proprietary **Dual-Pump™** topology
- I Selectable types of audio outputs: Class-AB/D/G
- I Filterless Class-D audio amplifier integrated with a Class-G charge pump regulator
- I Automatic level control to eliminate output clipping
- I Selectable ALC dynamic characteristics
- I Maximum output power (Non-ALC Mode)
 - 5.4W ($V_{DD}=3.7V$, THD+N=10%, $R_L=3\Omega+33\mu H$)
 - 5.0W ($V_{DD}=3.7V$, THD+N=10%, $R_L=4\Omega+33\mu H$)
 - 3.1W ($V_{DD}=3.7V$, THD+N=10%, $R_L=8\Omega+33\mu H$)
- I ALC output power (ALC Mode)
 - 4.6W ($V_{DD}=3.7V$, THD+N=0.6%, $R_L=3\Omega+33\mu H$)
 - 4.0W ($V_{DD}=3.7V$, THD+N=0.6%, $R_L=4\Omega+33\mu H$)
 - 2.4W ($V_{DD}=3.7V$, THD+N=0.6%, $R_L=8\Omega+33\mu H$)
- I Maximum Voltage Gain: 28dB
- I ALC dynamic range: 9dB
- I Low quiescent current: 4.5mA @ $V_{DD}=3.7V$
- I Low THD+N: 0.04% ($V_{DD}=3.7V$, $f=1kHz$, $R_L=4\Omega+33\mu H$, $P_o=0.5W$)
- I High PSRR: 68dB at 1kHz
- I Selectable fade-in time
- I Auto-recovering over-current and thermal-overload protection
- I Available in TSSOP-20L & QFN4x4-20L packages

APPLICATIONS

- I Blue Tooth Speakers
- I Smart Phones
- I Portable Consumer Electronic Devices

TYPICAL APPLICATION CIRCUIT

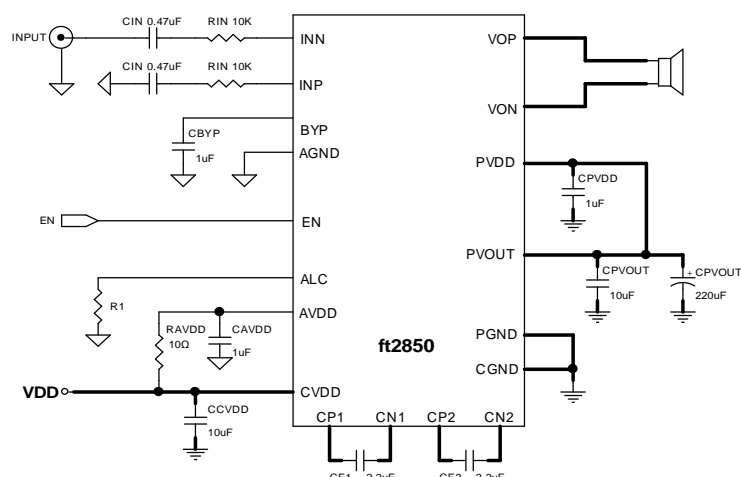

PIN ASSIGNMENT AND DESCRIPTION

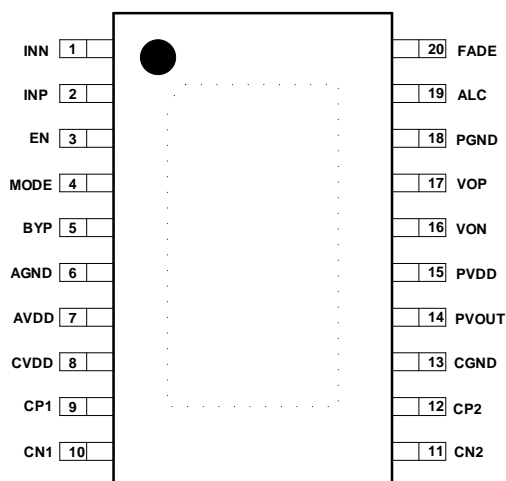

ft2850P (TOP VIEW)

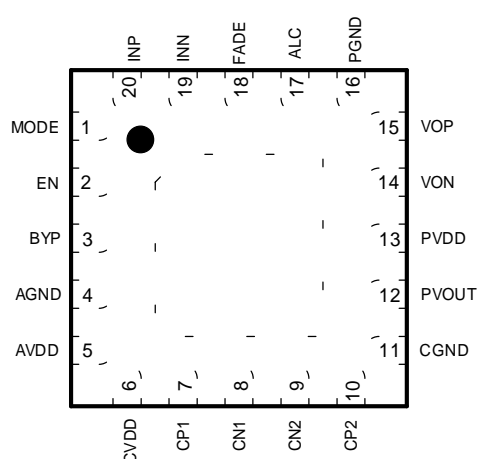

ft2850Q (TOP VIEW)

NAME	PIN #		PIN TYPE	DESCRIPTION
	TSSOP	QFN		
INN	1	19	AI	Inverting audio input.
INP	2	20	AI	Non-inverting audio input.
EN	3	2	DI	Chip Enable with an on-chip 300kΩ pulldown resistor to ground.
MODE	4	1	AI	Operating Mode Control with an on-chip 300kΩ pulldown resistor to ground.
BYP	5	3	AO	Common-mode voltage bias for the audio inputs. Connect to a 1μF capacitor for decoupling.
AGND	6	4	G	Analog ground. Connect to the system ground GND.
AVDD	7	5	P	Power supply input for analog circuitry. Connect to a 1μF capacitor for decoupling.
CVDD	8	6	P	Power supply input for the charge pump regulator. Connect to a 10μF capacitor for decoupling.
CP1	9	7	AO	Positive connection to the flying capacitor C_{F1} of the charge pump regulator.
CN1	10	8	AO	Negative connection to the flying capacitor C_{F1} of the charge pump regulator.
CN2	11	9	AO	Negative connection to the flying capacitor C_{F2} of the charge pump regulator.
CP2	12	10	AO	Positive connection to the flying capacitor C_{F2} of the charge pump regulator.
CGND	13	11	G	Power ground for the charge pump regulator. Connect to the system ground GND.
PVOUT	14	12	AO	Boosted voltage output of the charge pump regulator. Connect to a 10μF capacitor for decoupling. It must be externally shorted to PVDD on the system board.
PVDD	15	13	P	Power supply input for audio amplifier's output stage. Connect to a 1μF capacitor for decoupling. It must be externally shorted to PVOUT on the system board.
VON	16	14	AO	Inverting BTL audio output.
VOP	17	15	AO	Non-inverting BTL audio output.
PGND	18	16	G	Power ground for audio amplifier's output stage. Connect to the system ground GND.
ALC	19	17	AI	ALC Mode Select to set the ALC dynamic characteristic.
FADE	20	18	AI	Fade-In Time Select to set the fade-in time during startup.